

Downtown Walla Walla Parking Garage Conceptual Design



Engineering•Architectural•Planning
Land Surveying•Environmental



E ALDER

S COLVILLE

EXISTING CONTEXT



MASSING

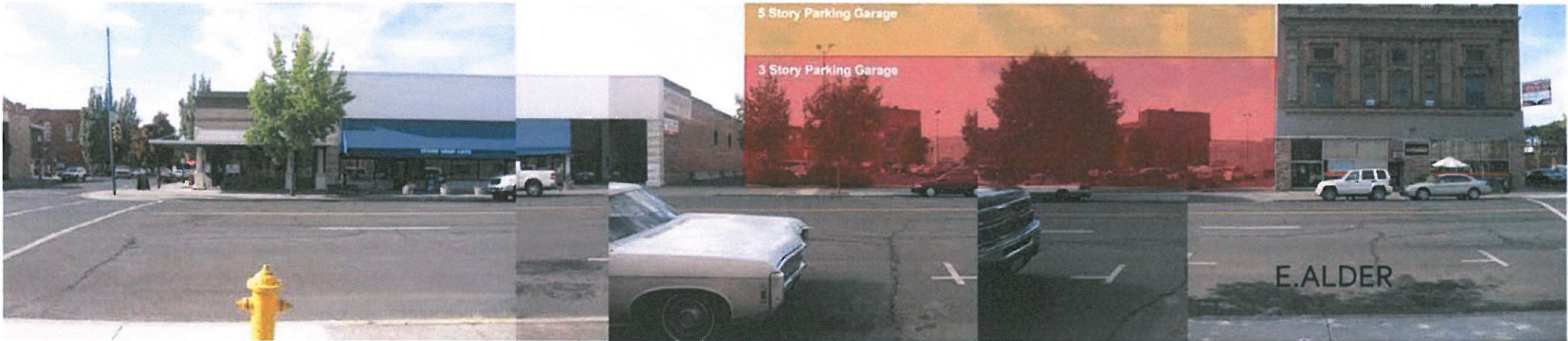



EXISTING PARKING
LOT
64 SPACES
INCLUDING (4) ADA

10/7/2011 12:27:20 PM 1:10360000\USKH\Projects\Garage_091001_1.rvt

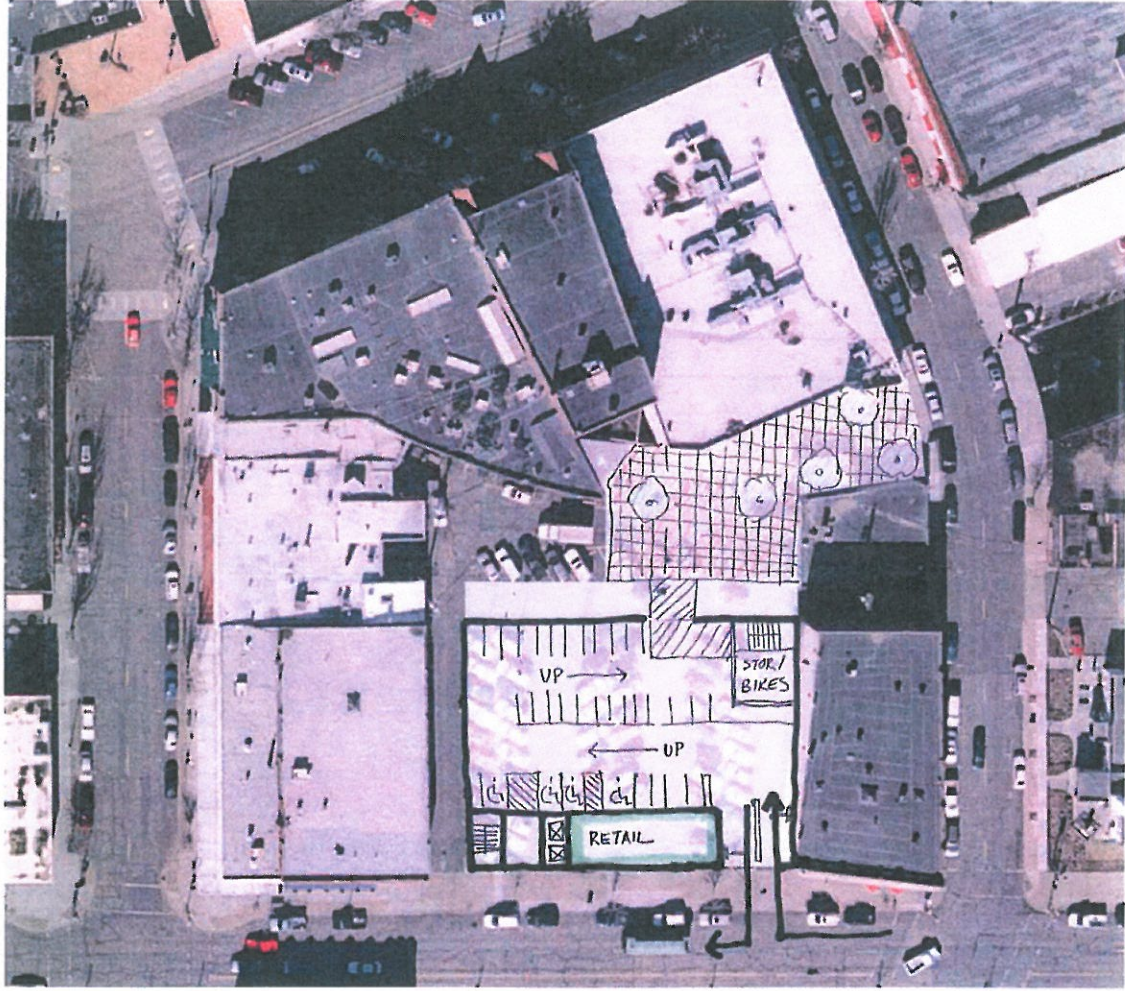

 <p>USKH United States Kiewit Construction 5 North Capital Blvd., Suite 200 Falls Church, VA 22042 Phone: 703.277.4822 www.uskh.com</p>	DOWNTOWN PARKING GARAGE 119 E. ALDER STREET 131000 Part of W&B Y&B		Section No. SITE-A
	Date Drawn Checked Approved	10/07/2011	131000

10/10/2011 12:47:20 PM \\11032000\highway\plans\garage option 1.rvt

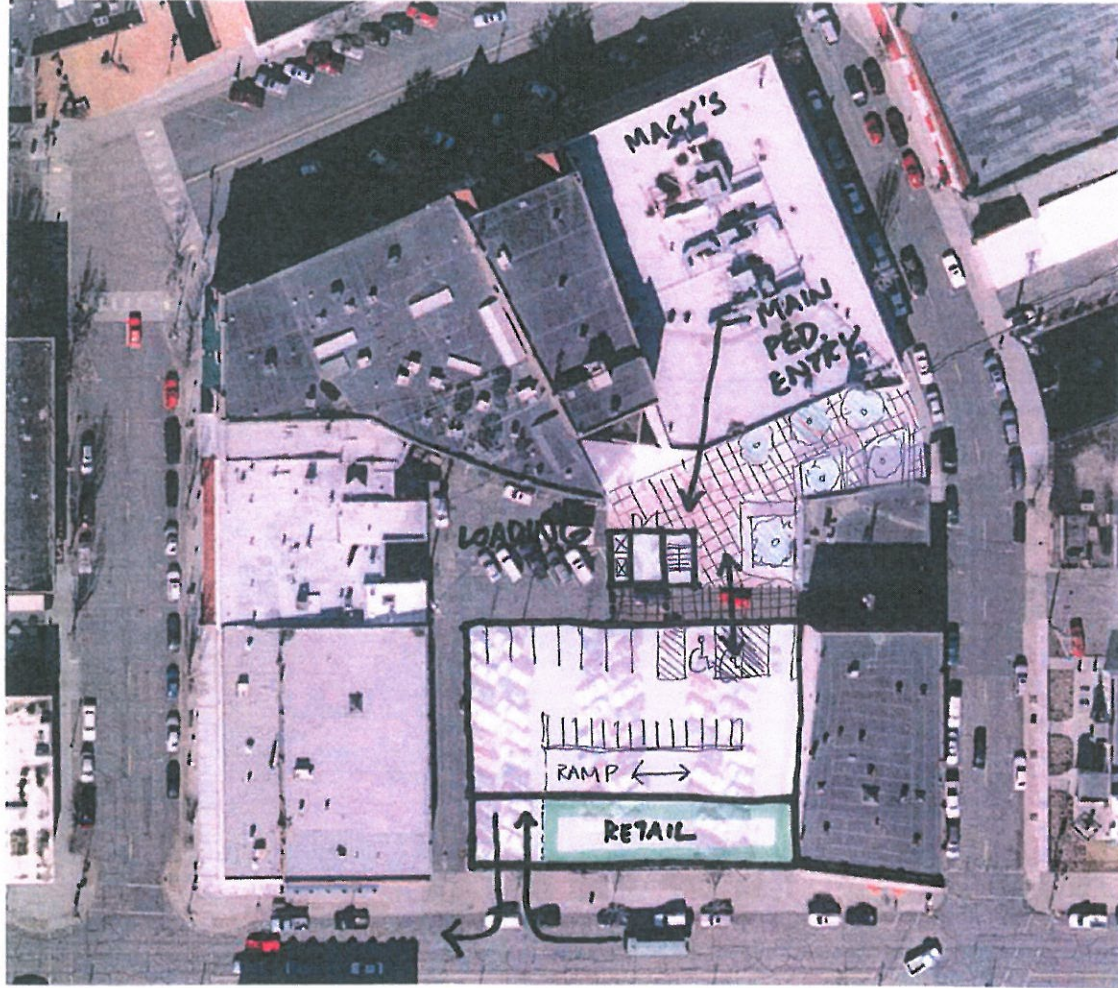

SITE-B

USKH <small>United States K&H 5 North College Street New York, NY 10003 Phone: 212.242.1143</small>		DOWNTOWN PARKING GARAGE 115 E. ALBANY STREET 10TH FLOOR <small>Part of Public Works</small>		Sheet No: SITE-B
		Date: 10/07/2011	Drawn: Check: USPH/MLD	1338/008

10/1/2011 12:27:11 PM K:\1330000\Drawings\1330000\stage option 1.rvt

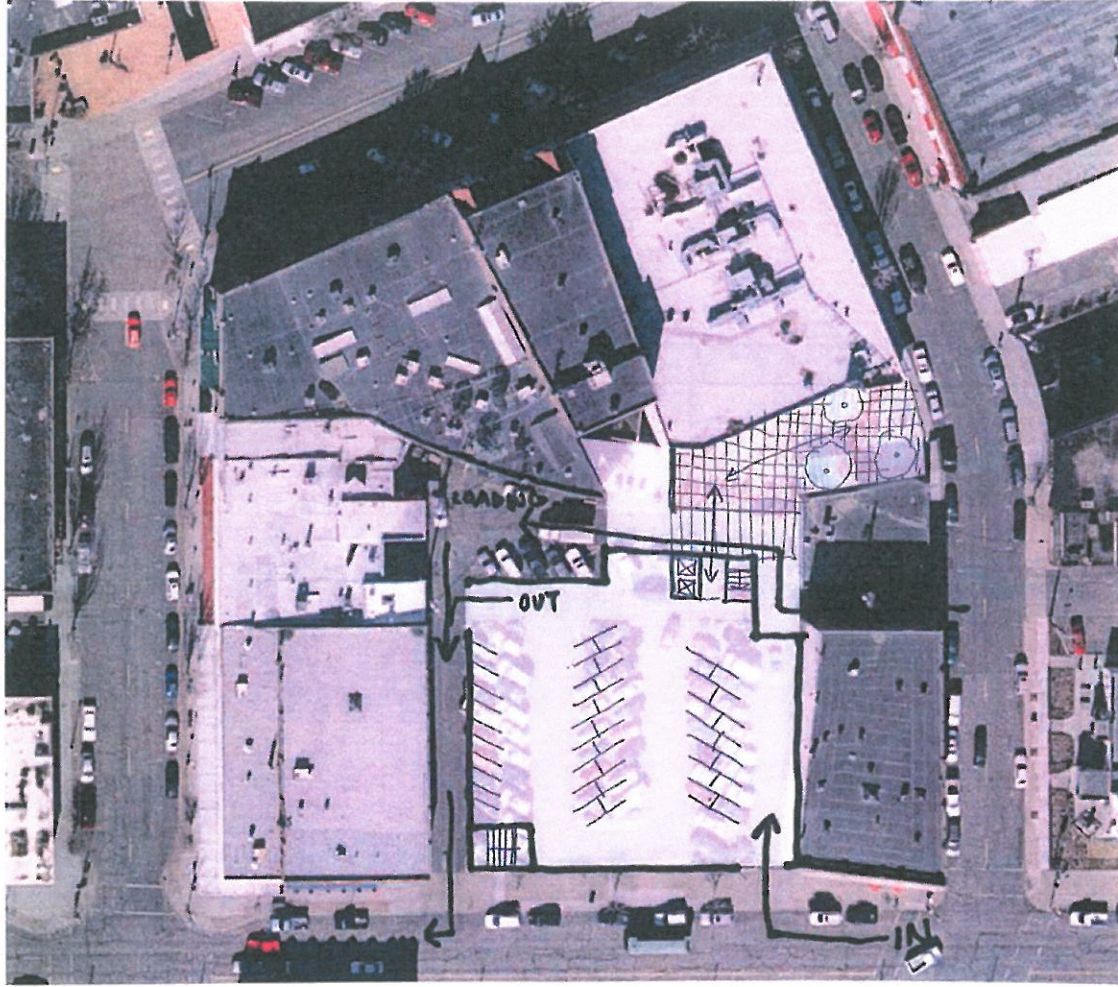

USKH 5 N. 4th Street New York, NY 10002 Phone: (201) 527-2443	DOWNTOWN PARKING GARAGE 115 E. ALDER STREET 1150000 Part of W 14th Block		Sheet No. SITE-C
	Date 10/07/2011	Drawn CHENNAI	Checked GUYUW

SITE-C

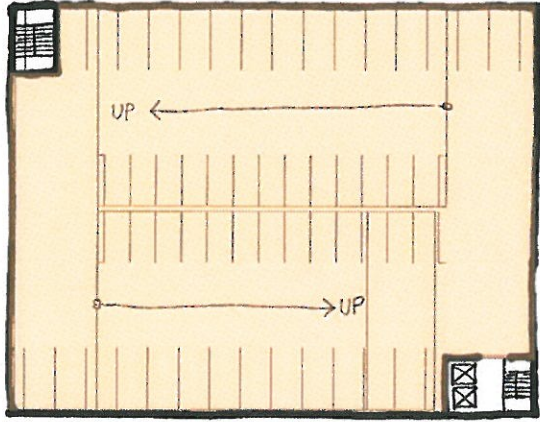

② Level 3
1/32" = 1'-0"

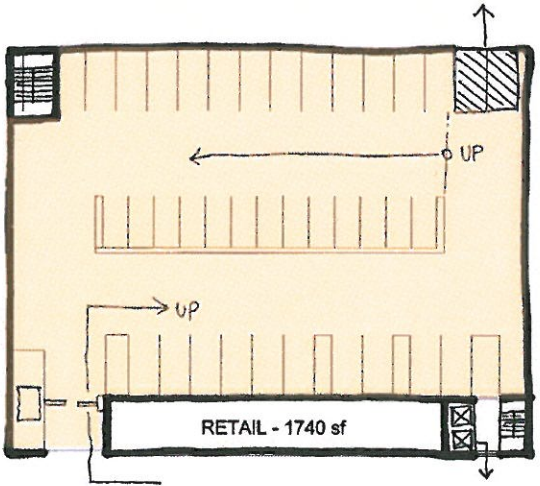

① Level 1
1/32" = 1'-0"

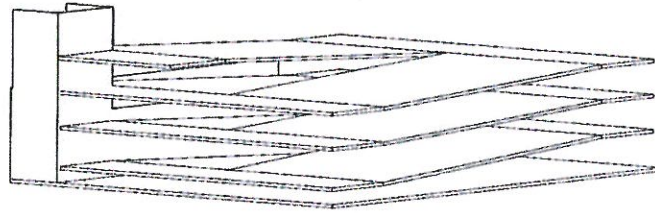

③ 3d view 1

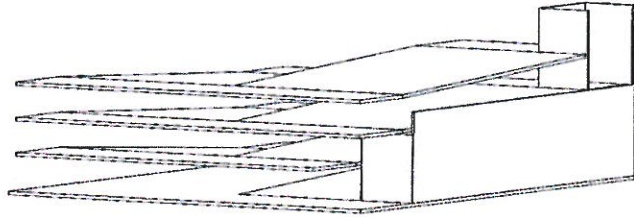

④ 3d view 2

GARAGE LAYOUT OPTION 1

3.5 STORY -
 COMPACT 63 SPACES
 STANDARD 90 SPACES
 TOTAL 153 SPACES

NET GAIN OF 89 PARKING SPACES

CONSTRUCTION COST -
 \$3.8 - \$4.4 MILLION

5 STORY -
 COMPACT 89 SPACES
 STANDARD 136 SPACES
 TOTAL 225 SPACES

NET GAIN OF 161 PARKING SPACES

CONSTRUCTION COST -
 \$5.1 - \$6.0 MILLION

11/11/2011 11:07:11 AM
 11/11/2011 11:07:11 AM
 11/11/2011 11:07:11 AM

Sheet No.: **OPT 1**
 Date: 10/07/2011
 Drawn: USKH P.C.L.
 Checked: USKH P.C.L.
 1336500

DOWNTOWN PARKING GARAGE
 119 E. LEXINGTON STREET
 1336500
 Part of Walk Walla

USKH
 USKH CONSULTING ARCHITECTS
 5 North Columbia Street
 Walla Walla, WA 99026
 Phone: (509) 562-1453
 www.uskh.com

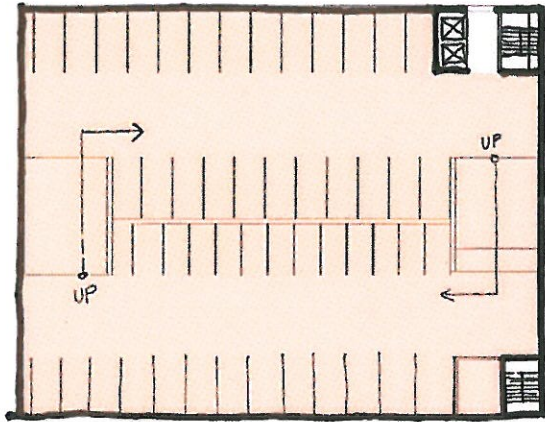

② Level 3
1/32" = 1'-0"

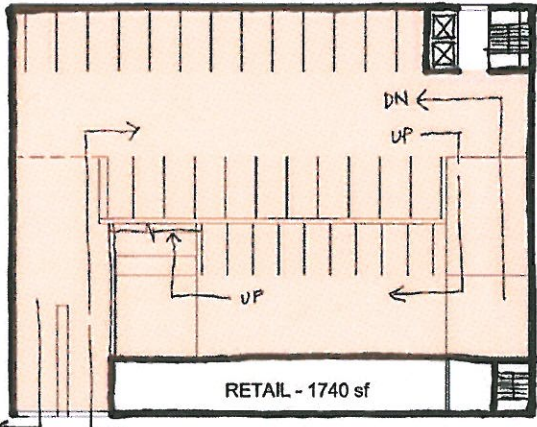

① Level 1
1/32" = 1'-0"

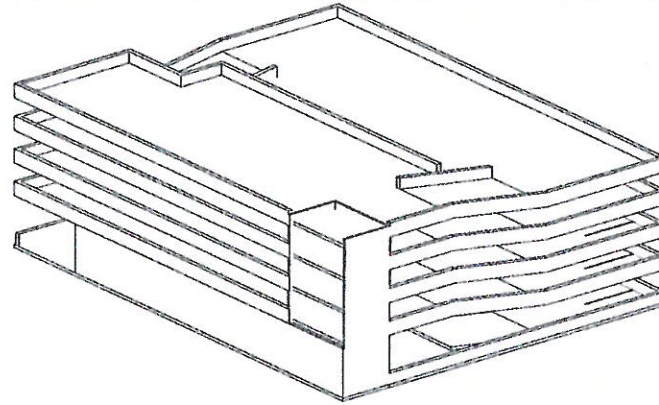

③ 3d view 1

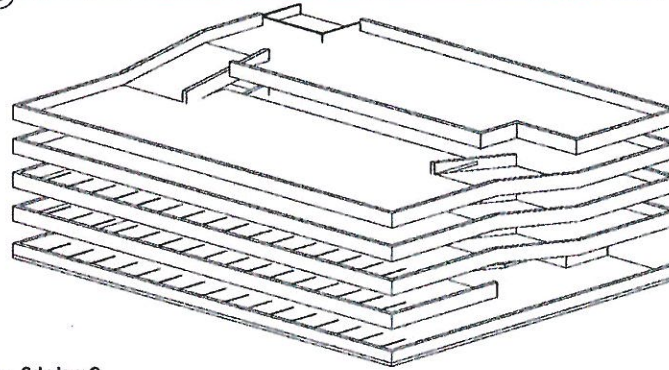

④ 3d view 2

GARAGE LAYOUT OPTION 2

3.5 STORY -
 COMPACT 64 SPACES
 STANDARD 104 SPACES
 TOTAL 168 SPACES

NET GAIN OF 104 PARKING SPOTS

CONSTRUCTION COST -
 \$3.8 - \$4.4 MILLION

5 STORY -
 COMPACT 120 SPACES
 STANDARD 130 SPACES
 TOTAL 250 SPACES

NET GAIN OF 186 PARKING SPOTS

CONSTRUCTION COST -
 \$5.1 - \$6.0 MILLION

11/2/2011 3:00:07 PM C:\Users\user\Documents\1113333333\1113333333.dwg

 USKH CONSULTING ENGINEERS ARCHITECTS 5 North Colwich Street Seattle, WA 98102 Phone: (206) 452-5252 www.uskh.com	DOWNTOWN PARKING GARAGE 119 E. LEXER STREET SEATTLE, WA 98102 PORT OF WALLA WALLA	SHEET NO.: OPT 2
	DATE: 10/27/2011 DRAWN: 133500 CHECKED: USKH Y.Q.Z.	SHEET NO.: 133500

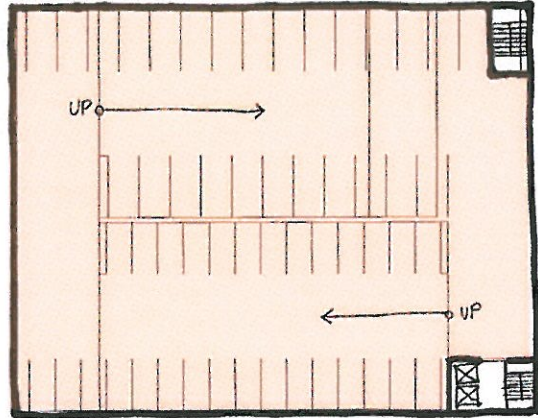

② Level 3
1/32" = 1'-0"

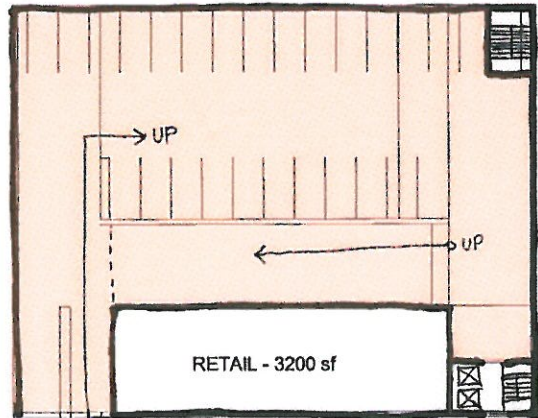

① Level 1
1/32" = 1'-0"

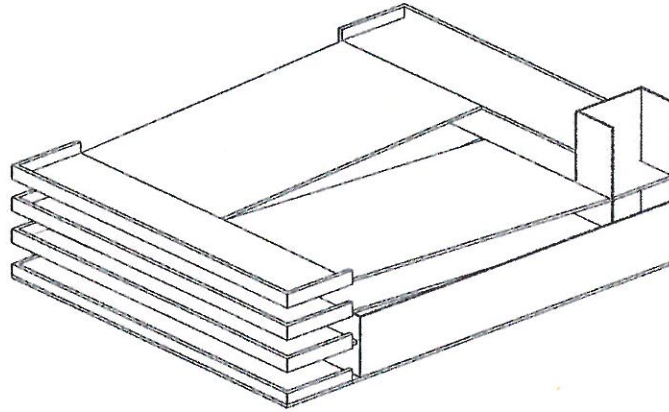

③ 3d view 1

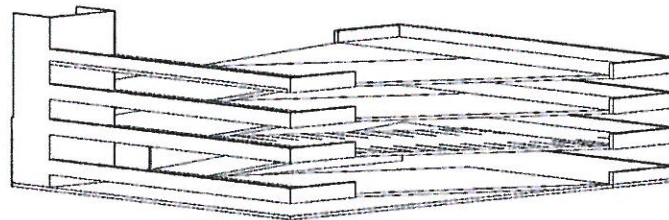

④ 3d view 2

GARAGE LAYOUT OPTION 3

3.5 STORY -
 COMPACT 58 SPACES
 STANDARD 104 SPACES
 TOTAL 162 SPACES

NET GAIN OF 98 PARKING SPOTS

CONSTRUCTION COST -
 \$3.8 - \$4.4 MILLION

5 STORY -
 COMPACT 116 SPACES
 STANDARD 131 SPACES
 TOTAL 247 SPACES

NET GAIN OF 183 PARKING SPOTS

CONSTRUCTION COST -
 \$5.1 - \$6.0 MILLION

11/21/2011 2:38:11 PM E:\133550\DWG\3DVIEW\3DVIEW.dwg

Sheet No: **OPT 3**
 10/17/2011
 Date: 10/17/2011
 Drawn: USKH W.O.
 Checked: USKH W.O.
 1335500

DOWNTOWN PARKING GARAGE
 119 E. ALDER STREET
 1335500
 PORT OF WALLA WALLA

USKH
 United States Korea
 5 North Colfax Street
 Walla Walla, WA 99062
 Phone: (509) 252-2425
 www.uskh.com

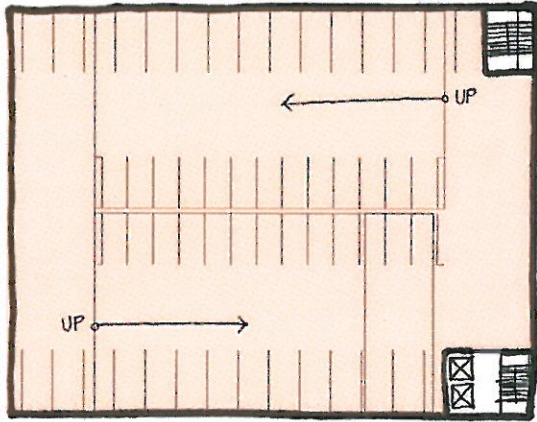

② Level 3
1/32" = 1'-0"

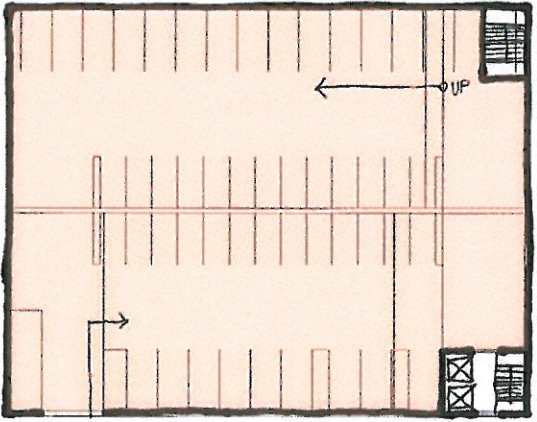

① Level 1
1/32" = 1'-0"

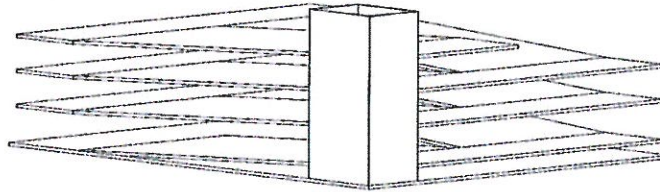

③ 3d view 1

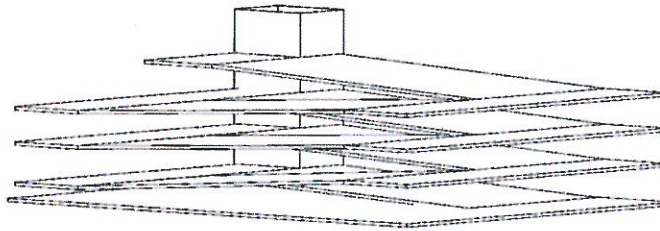

④ 3d view 2

GARAGE LAYOUT OPTION 4

3.5 STORY -
 COMPACT 91 SPACES
 STANDARD 96 SPACES
 TOTAL 187 SPACES

NET GAIN OF 123 PARKING SPOTS

CONSTRUCTION COST -
 \$3.8 - \$4.4 MILLION

5 STORY -
 COMPACT 130 SPACES
 STANDARD 142 SPACES
 TOTAL 272 SPACES

NET GAIN OF 208 PARKING SPOTS

CONSTRUCTION COST -
 \$5.1 - \$6.0 MILLION

11/2/2011 2:50:10 PM \\13300001\USK\Projects\Garage Option 4.rvt

Sheet No: **OPT 4**
 Date: 1/27/11
 Drawn: 133500
 Checked: USK/W.O.
 Project No: 133500

DOWNTOWN PARKING GARAGE
 119 E ALDER STREET
 133500
 PORT OF WALLA WALLA

USKH
 USK HOLDINGS, LLC
 5 North Colville Street
 Walla Walla, WA 99052
 Phone: (509) 825-4424
 www.usk4.com

